

INSTALLER: THESE INSTRUCTIONS MUST BE CONVEYED TO AND REMAIN WITH THE HOMEOWNER.

CERTIFIED UNDER CANADIAN AND AMERICAN NATIONAL STANDARDS,
CSA 2.33, AND ANSI Z21.88 RESPECTIVELY FOR VENTED GAS-FIRED SPACE HEATING APPLIANCES.



FIREPLACES

LISTED DIRECT VENT MILLIVOLT
GAS-FIRED WALL FURNACE

INSTALLATION AND OPERATION INSTRUCTIONS FOR:
NATURAL GAS MODEL **GD25 - N**
PROPANE GAS MODEL **GD25 - P**

CERTIFIED FOR CANADA AND UNITED STATES USING ANSI / AGA / CGA METHODS

WARNING: If the information in these instructions is not followed exactly, a fire or explosion may result causing property damage, personal injury or death.

FOR YOUR SAFETY

Do not store or use gasoline or other flammable vapours and liquids in the vicinity of this or any other appliance.

WHAT TO DO IF YOU SMELL GAS:

- Do not try to light any appliance.
- Do not touch any electrical switch.
- Do not use any phone in your building.
- Immediately call your gas supplier from a neighbour's phone. Follow the gas supplier's instructions.
- If you cannot reach your gas supplier, call the fire department.

Installation and service must be performed by a qualified installer, service agency or the gas supplier.

**Wolf Steel Ltd., RR#1, 9 Napoleon Rd.,
Barrie, On., Canada L4M 4Y8 (705)721-1212**

Fax: (705)722-6031 Email: ask@napoleon.on.ca
Web: www.napoleon.on.ca



WS-415-099/03.16.99

NAPOLEON gas fireplaces are manufactured under the strict Standard of the world recognized ISO9002 Quality Assurance Certificate.

NAPOLEON products are designed with superior components and materials, assembled by trained craftsmen who take great pride in their work. The burner and valve assembly are leak and test-fired at a quality test station. The complete fireplace is thoroughly inspected by a qualified technician before packaging to ensure that you, the customer, receives the quality product that you expect from NAPOLEON.

NAPOLEON GAS FIREPLACE PRESIDENT'S LIFETIME LIMITED WARRANTY

The following materials and workmanship in your new NAPOLEON gas fireplace are warranted against defects for as long as you own the fireplace. This covers: combustion chamber, heat exchanger, stainless steel burner, phazer™ logs and embers, ceramic glass (thermal breakage only), gold plated parts against tarnishing, porcelainized enamelled components and aluminum extrusion trims.

Electrical (110V and millivolt) components and wearable parts such as blowers, gas valves, thermal switch, switches, wiring, remote controls, ignitor, gasketing, and pilot assembly are covered and NAPOLEON will provide replacement parts free of charge during the first year of the limited warranty.

Labour related to warranty repair is covered free of charge during the first year. Repair work, however, requires the prior approval of an authorized company official. Labour costs to the account of NAPOLEON are based on a predetermined rate schedule and any repair work must be done through an authorized NAPOLEON dealer.

CONDITIONS AND LIMITATIONS

NAPOLEON warrants its products against manufacturing defects to the original purchaser only -- i.e., the individual or legal entity (registered customer) whose name appears on the warranty registration card filed with NAPOLEON -- provided that the purchase was made through an authorized NAPOLEON dealer and is subject to the following conditions and limitations:

This factory warranty is nontransferable and may not be extended whatsoever by any of our representatives.

The gas fireplace must be installed by a licenced, authorized service technician or contractor. Installation must be done in accordance with the installation instructions included with the product and all local and national building and fire codes.

This limited warranty does not cover damages caused by misuse, lack of maintenance, accident, alterations, abuse or neglect and parts installed from other manufacturers will nullify this warranty.

This limited warranty further does not cover any scratches, dents, corrosion or discolouring caused by excessive heat, abrasive and chemical cleaners nor chipping on porcelain enamel parts, mechanical breakage of PHAZER™ logs and embers, nor any venting components used in the installation of the fireplace.

NAPOLEON warrants its stainless steel burners against defects in workmanship and material for life, subject to the following conditions: During the first 10 years NAPOLEON will replace or repair the defective parts at our option free of charge. From 10 years to life, NAPOLEON will provide replacement burners at 50% of the current retail price.

In the first year only, this warranty extends to the repair or replacement of warranted parts which are defective in material or workmanship provided that the product has been operated in accordance with the operation instructions and under normal conditions.

After the first year, with respect to this President's Limited Lifetime Warranty, NAPOLEON may, at its discretion, fully discharge all obligations with respect to this warranty by refunding to the original warranted purchaser the wholesale price of any warranted but defective part(s).

After the first year, NAPOLEON will not be responsible for installation, labour or any other costs or expenses related to the reinstallation of a warranted part, and such expenses are not covered by this warranty.

Notwithstanding any provisions contained in this President's Limited Lifetime Warranty, NAPOLEON'S responsibility under this warranty is defined as above and it shall not in any event extend to any incidental, consequential or indirect damages.

This warranty defines the obligations and liability of NAPOLEON with respect to the NAPOLEON gas fireplace and any other warranties expressed or implied with respect to this product, its components or accessories are excluded.

NAPOLEON neither assumes, nor authorizes any third party to assume, on its behalf, any other liabilities with respect to the sale of this product. NAPOLEON will not be responsible for: over-firing, downdrafts, spillage caused by environmental conditions such as rooftops, buildings, nearby trees, hills, mountains, inadequate vents or ventilation, excessive venting configurations, insufficient makeup air, or negative air pressures which may or may not be caused by mechanical systems such as exhaust fans, furnaces, clothes dryers, etc.

Any damages to fireplace, combustion chamber, heat exchanger, brass trim or other component due to water, weather damage, long periods of dampness, condensation, damaging chemicals or cleaners will not be the responsibility of NAPOLEON.

The bill of sale or copy will be required together with a serial number and a model number when making any warranty claims from your authorized dealer. The warranty registration card must be returned within fourteen days to register the warranty.

NAPOLEON reserves the right to have its representative inspect any product or part thereof prior to honouring any warranty claim.

ALL SPECIFICATIONS AND DESIGNS ARE SUBJECT TO CHANGE WITHOUT PRIOR NOTICE DUE TO ON-GOING PRODUCT IMPROVEMENTS. NAPOLEON® IS A REGISTERED TRADEMARK OF WOLF STEEL LTD. PATENTS U.S. 5.303.693.801 - CAN. 2.073.411, 2.082.915. © WOLF STEEL LTD.



PLEASE RETAIN THIS MANUAL FOR FUTURE REFERENCE

TABLE of CONTENTS

PG 2-4 INTRODUCTION	PG 16	OPTIONAL BLOWER INSTALLATION
Warranty	17	OPTIONAL FAN & THERMOSTATIC SENSOR
General Instructions	18	OPERATION / MAINTENANCE
General Information	Operating Instructions	Maintenance
Care of Glass & Plated Parts	19	ADJUSTMENTS
5-6 VENTING	Pilot Burner Adjustment	Venturi Adjustment
Venting Lengths	20-21 REPLACEMENTS	Ordering Replacement Parts
Air Terminal Locations	Replacement Parts	Accessories
7-13 INSTALLATION	Vent Kits	Terminal Kits
Wall & Ceiling Protection	22-23 TROUBLE SHOOTING GUIDE	
Using Flexible Vent Components		
Using Rigid Vent Components		
Gas Installation		
Mobile Home Installation		
Framing		
14-15 FINISHING		
Log Placement		
Optional Glowing Ember Installation		
Door Removal & Installation		

GENERAL INSTRUCTIONS

THIS GAS FIREPLACE SHOULD BE INSTALLED AND SERVICED BY A QUALIFIED INSTALLER to conform with local codes. In absence of local codes, install to the current CAN/CGA -B149 Installation Code in Canada or to the National Fuel Gas Code, ANSI Z223.1, and NFPA 54 in the United States. Mobile home installation must conform with local codes or in the absence of local codes, install to the current standard for gas equipped mobile housing CAN/CSA ZA240 MH Series in Canada or ANSI Z223.1 and NFPA 54 in the United States.

Purge all gas lines with the glass door of the fireplace removed. Assure that a continuous gas flow is at the burner before installing the door.

Under extreme vent configurations, allow several minutes (5-15) for the flame to stabilize after ignition.

Eight (8") inches is the minimum bend radius allowed for the 7" diameter flexible air liner.

This fireplace may be installed in an aftermarket permanently located, manufactured (mobile) home, where not prohibited by local codes.

This fireplace is only for use with the type of gas indicated on the rating plate. This fireplace is not convertible for use with other gases, unless a certified kit is used.

The fireplace and its individual shutoff valve must be disconnected from the gas supply piping system during any pressure testing of that system at test pressures in excess of 1/2 psig (3.5 kPa). The fireplace must be isolated from the gas supply piping system by closing its individual manual shutoff valve during any pressure testing of the gas supply piping system at test pressures equal to or less than 1/2 psig (3.5 kPa).

When the fireplace is installed directly on carpeting, vinyl tile or other combustible material other than wood flooring, the fireplace shall be installed on a metal or wood panel extending the full width and depth.

The optional fan or blower is supplied with a cord. If installed, the junction box must be electrically connected and grounded in accordance with local codes. In the absence of local codes, use the current CSA C22.1 CANADIAN ELECTRICAL CODE in Canada or the ANSI/NFPA 70-1996 NATIONAL ELECTRICAL CODE in the United States.

4 GENERAL INFORMATION

FOR YOUR SATISFACTION, THIS FIREPLACE HAS BEEN TEST-FIRED TO ASSURE ITS OPERATION AND QUALITY! Maximum input is 25,000 BTU/hr for natural gas and propane. When the fireplace is installed at elevations above 4,500ft, and in the absence of specific recommendations from the local authority having jurisdiction, the certified high altitude input rating shall be reduced at the rate of 4% for each additional 1,000ft. Maximum output for natural gas is 19,500 BTU/hr at an efficiency of 78% with the fan on; and 20,250 BTU/hr for propane at an efficiency of 81% with the fan on. Maximum A.F.U.E. (annual fuel utilization efficiency) rating is 69% for natural gas and 70% for propane. Minimum A.F.U.E. rating is 63% for natural gas and propane.

Minimum inlet gas supply pressure is 4.5 inches water column for natural gas and 11 inches water column for propane. Maximum inlet gas pressure is 7 inches water column for natural gas and 13 inches water column for propane. Manifold pressure under flow conditions is 3.5 inches water column for natural gas and 10 inches water column for propane. This fireplace is approved for bathroom, bedroom and bed-sitting room installations and is suitable for mobile home installation. The natural gas model can only be installed in a mobile home that is permanently positioned on its site and fueled with natural gas.

NO EXTERNAL ELECTRICITY (110 VOLTS OR 24 VOLTS) IS REQUIRED FOR THE GAS SYSTEM OPERATION. Expansion / contraction noises during heating up and cooling down cycles are normal and are to be expected.

PROVIDE ADEQUATE VENTILATION AND COMBUSTION AIR. PROVIDE ADEQUATE ACCESSIBILITY CLEARANCE FOR SERVICING AND OPERATING THE FIREPLACE. NEVER OBSTRUCT THE FRONT OPENING OF THE FIREPLACE.

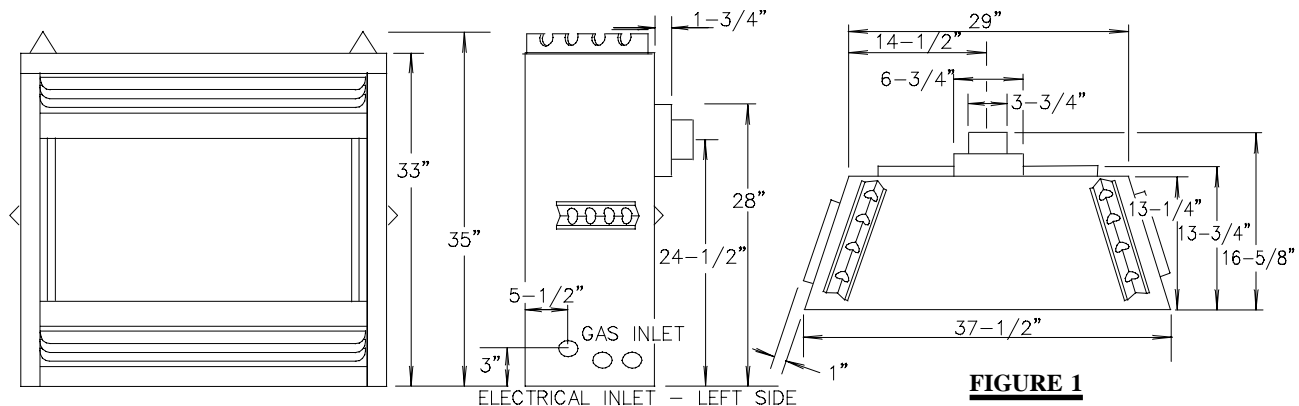

FIGURE 1

CARE OF GLASS, AND PLATED PARTS

Do not use abrasive cleaners to clean plated parts. Buff lightly with a clean dry cloth. The glass is 3/16" ceramic glass available from your Napoleon / Wolf Steel Ltd. dealer. DO NOT SUBSTITUTE MATERIALS. Clean the glass after the first 10 hours of operation with a recommended gas fireplace glass cleaner. Thereafter clean as required. DO NOT CLEAN GLASS WHEN HOT! If the glass is not kept clean permanent discoloration and / or blemishes may result.

WARNING

- Do not burn wood or other materials in this fireplace.
- Adults and especially children should be alerted to the hazards of high surface temperatures and should stay away to avoid burns or clothing ignition. Supervise young children when they are in the same room as the fireplace.
- Due to high temperatures, the fireplace should be located out of traffic and away from furniture and draperies.
- Clothing or other flammable material should not be placed on or near the fireplace.
- Any safety screen or guard removed for servicing must be replaced prior to operating the fireplace.
- It is imperative that the control compartments, burners and circulating blower and its passageway in the fireplace and venting system are kept clean. The fireplace and its venting system should be inspected before use and at least annually by a qualified service person. More frequent cleaning may be required due to excessive lint from carpeting, bedding material, etc. The fireplace area must be kept clear and free from combustible materials, gasoline and other flammable vapours and liquids.
- Under no circumstances should this fireplace be modified.
- This fireplace must not be connected to a chimney flue pipe serving a separate solid fuel burning appliance.
- Do not use this fireplace if any part has been under water. Immediately call a qualified service technician to inspect the fireplace and to replace any part of the control system and any gas control which has been under water.
- Do not operate the fireplace with the glass door removed, cracked or broken. Replacement of the glass should be done by a licensed or qualified service person. Use only with a glass door certified with the fireplace.
- Do not strike or slam shut the fireplace glass door.

VENTING

VENTING LENGTHS AND AIR TERMINAL LOCATIONS

Use only Napoleon or Simpson Dura-Vent Model DV-GS venting components. Minimum and maximum vent lengths, for both horizontal and vertical installations, and air terminal locations for either system are set out in this manual and must be adhered to. For Simpson Dura-Vent, follow the installation procedure provided with the venting components.

NOTE: Both Wolf Steel and Simpson Dura-Vent require the 4 inch and the 7 inch diameter vent joints to be sealed. Use the high temperature sealant provided.

When using Napoleon venting components, use only the following vent kits: WALL TERMINAL KIT **GD222**, or 1/12 TO 7/12 PITCH ROOF TERMINAL KIT **GD110**, 8/12 TO 12/12 ROOF TERMINAL KIT **GD111**, FLAT ROOF TERMINAL KIT **GD112** or PERISCOPE KIT **GD201** (for wall penetration below grade) in conjunction with the various terminations, use either the 5 foot vent kit **GD220** or the 10 foot vent kit **GD330**.

These vent kits allow for either horizontal or vertical venting of the fireplace. **FIGURES 2, 3, & 4.** The maximum number of 4" flexible connections is two horizontally or three vertically (excluding the fireplace and the air terminal connections). For optimum flame appearance and fireplace performance, keep the vent length and number of elbows to a minimum. The air terminal must remain unobstructed at all times. Examine the air terminal at least once a year to verify that it is unobstructed and undamaged.

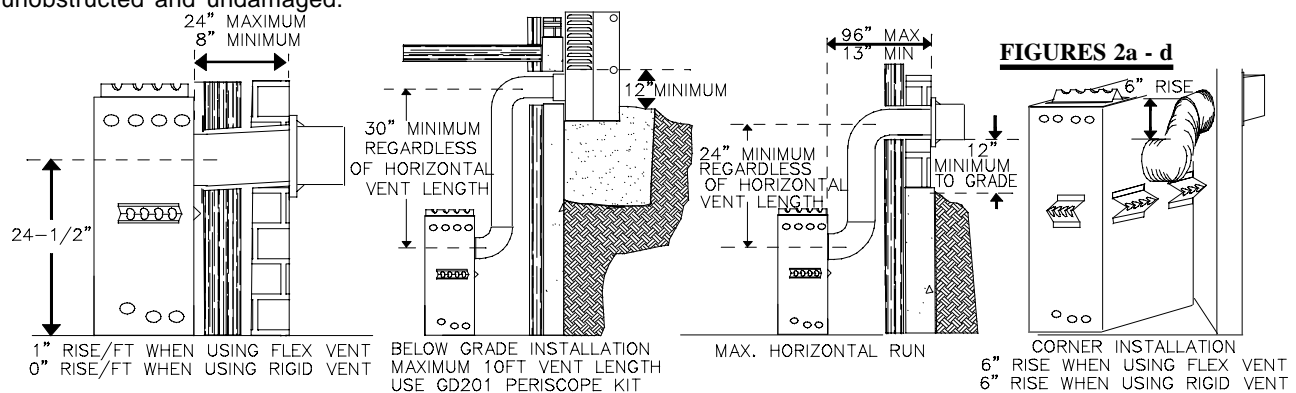

Horizontal runs can have a 0 inch rise per foot using Simpson Dura-Vent, Napoleon rigid or flexible venting components when venting as illustrated in Figure 2a - c.

Provide a means for visually checking the vent connection to the fireplace after the fireplace is installed.

Do not allow the inside liner to bunch up on horizontal or vertical runs and elbows. Keep it pulled tight. A 1-1/4" air gap between the inner and outer liner all around is required for safe operation.

Use a firestop when penetrating interior walls, floor or ceiling.

Vent lengths that pass through unheated spaces (attics, garages, crawl spaces) should be insulated with insulation and wrapped in a protective sleeve to minimize condensation.

Minimum clearance to combustible construction from fireplace to vent surfaces:

sides, back, bottom, and top	0 inches
vent pipe	1 inch
recessed depth	13-3/4 inches

When venting, the horizontal run must be kept to a minimum of 8 inches or a maximum of 24 inches. If a greater horizontal run is required, the fireplace must have a minimum vertical rise immediately off the fireplace of 24 inches. With this configuration, the horizontal run can be between a minimum of 13 inches and a maximum of 96 inches. **FIGURE 2a-b.** When terminating vertically, the vertical rise is a minimum 36 inches and a maximum 40 feet from the centre of the fireplace flue outlet. **FIGURE 3.**

For safe and proper operation of the fireplace, follow the venting instructions exactly.

On all horizontal runs, when determining air terminal locations, check for appropriate rise per foot requirements.

A terminal shall not terminate directly above a sidewalk or paved driveway which is located between two single family dwellings and serves both dwellings. Local codes or regulations may require different clearances.

Do not allow the inside liner to bunch up on horizontal or vertical runs and elbows. Keep it pulled tight. A 1/4" air gap all around between the inner liner and outer liner is required for safe operation. Use a firestop when penetrating interior walls, floor or ceiling.

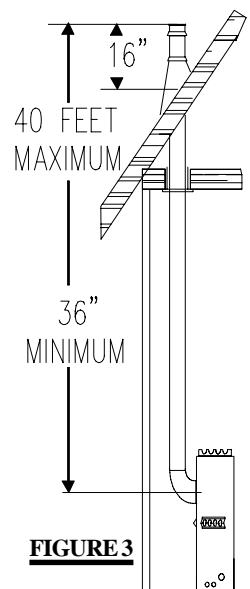

FIGURE 3

6 AIR TERMINAL INSTALLATIONS:

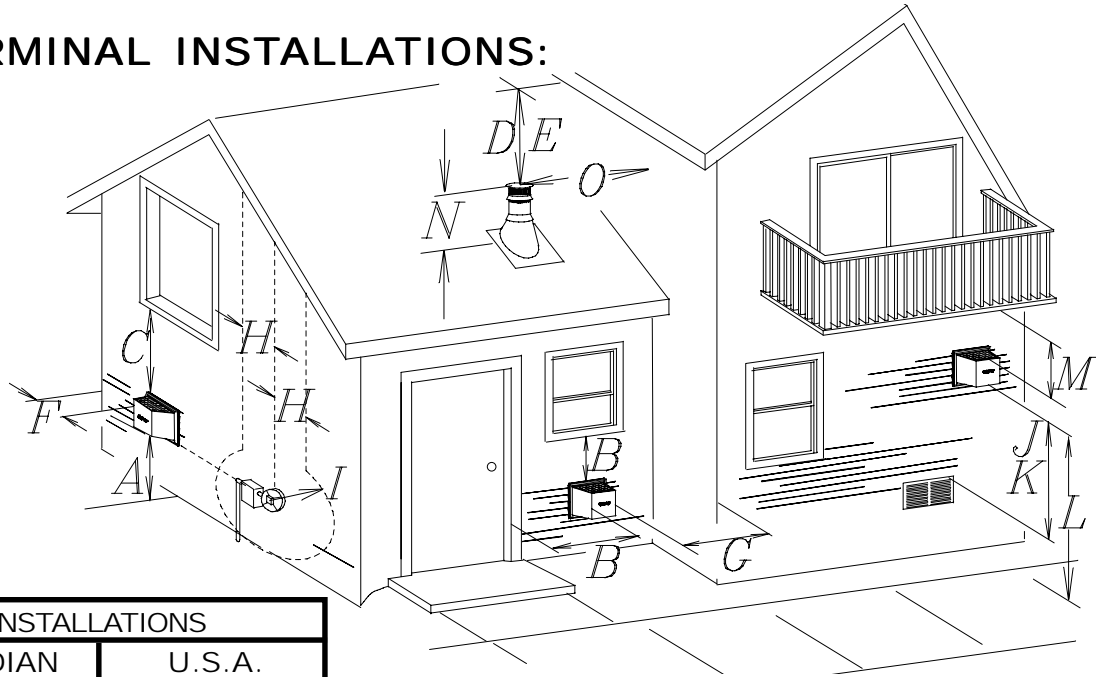

FIGURE 4

INSTALLATIONS			
	CANADIAN	U.S.A.	
A	12 INCHES	12 INCHES	Clearance above grade, veranda porch, deck or balcony.
B	12 INCHES	9 INCHES	Clearance to windows or doors that open.
C	12 INCHES*	12 INCHES*	Clearance to permanently closed windows.
D	18 INCHES**	18 INCHES**	Vertical clearance to ventilated soffit located above the terminal within a horizontal distance of 2 feet from the centerline of the terminal.
E	12 INCHES**	12 INCHES**	Clearance to unventilated soffit.
F	0 INCHES	0 INCHES	Clearance to an outside corner wall.
G	0 INCHES***	2 INCHES***	Clearance to an inside <i>non</i> -combustible corner wall or protruding <i>non</i> -combustible obstructions (chimney, etc.).
	0 POUÇES***	0 POUÇES***	Clearance to an inside combustible corner wall or protruding combustible obstructions (vent chase, etc.).
H	3 FEET	3 FEET****	Clearance to each side of the centerline extended above the meter / regulator assembly.
I	6 FEET	3 FEET****	Clearance to a service regulator vent outlet.
J	12 INCHES	9 INCHES	Clearance to a non-mechanical air supply inlet to the building or a combustion air inlet to any other appliance.
K	6 FEET	3 FEET†	Clearance to a mechanical air supply inlet.
L	7 FEET‡	7 FEET****	Clearance above a paved sidewalk or paved driveway located on public property unless fitted with a heat shield kit GD-301.
M	12 INCHES††	12 INCHES****	Clearance under a veranda, porch, deck or balcony.
N	16 INCHES	16 INCHES	Clearance above the roof.
O	2 FEET†*	2 FEET†*	Clearance from an adjacent wall including neighbouring buildings.

* Recommended to prevent condensation on windows and thermal breakage
 ** It is recommended to use a heat shield and to maximize the distance to vinyl clad soffits.
 *** The periscope GD-201 requires a minimum 18 inches clearance from an inside corner.
 **** This is a recommended distance. For additional requirements check local codes.
 † Three feet above if within 10 feet horizontally.
 ‡ A vent shall not terminate directly above a sidewalk or paved driveway that is located between two single family dwellings and serves both dwellings.
 †† Permitted only if the veranda, porch, deck or balcony is fully open on a minimum of two sides beneath the floor.
 †* Recommended to prevent recirculation of exhaust products. For additional requirements check local codes.

INSTALLATION

WALL AND CEILING PROTECTION

FOR SAFE AND PROPER OPERATION OF THE FIREPLACE, FOLLOW THE VENTING INSTRUCTIONS EXACTLY.

HORIZONTAL INSTALLATION: This application occurs when venting through an exterior wall. **FIGURES 2a-c.** Having determined the air terminal location, cut and frame a hole in an exterior wall with a minimum square or round opening of 9½". (As an alternative to framing, a vent pipe shield may be installed, ensuring a 1" clearance to combustibles. **See Figure 6.**)

1. Mark and cut the vent pipe shield to the determined depth of the combustible wall. Apply a bead of caulking (not supplied) to the framework or to the shield plate (in the case of a finished wall) and secure the shield through the opening to the interior wall. *The final location of the vent pipe shield should maintain the required clearance to the 7" vent pipe / liner.* Do not fill this cavity with any type of material. Apply a bead of caulking all around and place a firestop spacer over the vent shield to restrict cold air from being drawn into the room or around the fireplace. Ensure that both spacer and shield maintain the required clearance to combustibles. Once the vent pipe / liner is installed in its final position, apply sealant between the pipe / liner and the firestop spacer.

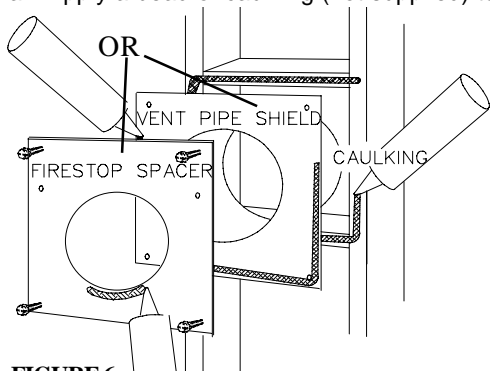

FIGURE 6

various roof pitches are available from your Napoleon dealer. See Accessories to order the specific kit required.

1. Determine the air terminal location, cut and frame 9½ inch openings in the ceiling and the roof to provide the minimum 1 inch clearance between the fireplace pipe / liner and any combustible material. Try to center the exhaust pipe location midway between two joist to prevent having to cut them. Use a plumb bob to line up the center of the openings.

DO NOT FILL THIS SPACE WITH ANY TYPE OF MATERIAL.

A vent pipe shield will prevent any materials such as insulation, from filling up the 1" air space around the pipe. **FIGURE 9.** Nail headers between the joist for extra support.

2. Apply a bead of caulking (not supplied) to the framework or to the Wolf Steel vent pipe shield plate or equivalent (in the case of a finished ceiling), and secure over the opening in the ceiling. **FIGURE 8.** A firestop must be placed on the bottom of each framed opening in a roof or ceiling that the venting system passes through. **FIGURE 7.** Apply a bead of caulking all around and place a firestop spacer over the vent shield to restrict cold air from being drawn into the room or around the fireplace. Ensure that both spacer and shield maintain the required clearance to combustibles. Once the vent pipe / liner is installed in its final position, apply sealant between the pipe / liner and the firestop spacer.

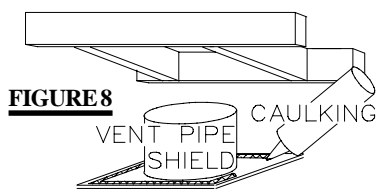

FIGURE 8

3. In the attic, after the pipe / liner has been installed, slide the vent pipe collar down to cover up the open end of the shield and tighten. This will prevent any materials, such as insulation, from filling up the 1" air space around the pipe.

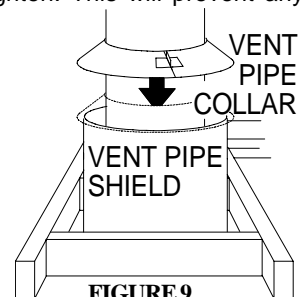

FIGURE 9

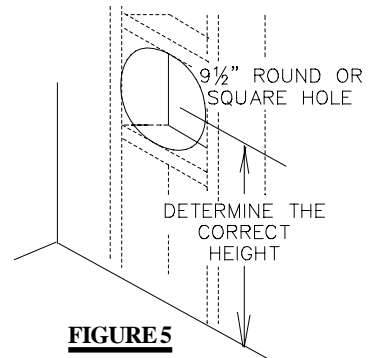

FIGURE 5

VERTICAL INSTALLATION: This application occurs when venting through a roof. **FIGURE 3.** Installation kits for

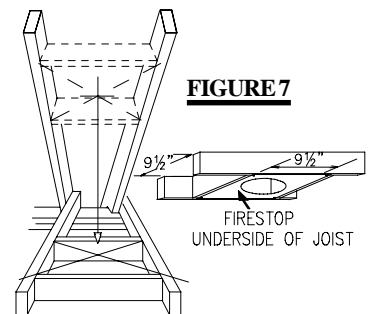

FIGURE 7

8 USING FLEXIBLE VENT COMPONENTS

FOR SAFE AND PROPER OPERATION OF THE FIREPLACE, FOLLOW THE VENTING INSTRUCTIONS EXACTLY.

HORIZONTAL AIR TERMINAL INSTALLATION

1. Stretch the 4" diameter aluminum flexible liner to the required length taking into account the additional length needed for the finished wall surface. Apply a heavy bead of the high temperature sealant, supplied with the unit, to the inside of the 4" liner approximately 1" from the end. Slip the liner a minimum of 2" over the fireplace vent collar and secure with 3 #8 screws.

2. Using the 7" diameter flexible aluminum liner, apply sealant, slide a minimum of 2" over the fireplace combustion air collar and secure with 3 #8 screws.

3. Insert the liners through the firestop. Position and secure the fireplace using the nailing tabs (2 per side) and/or secure to the floor using screws inserted through the two 1/4" diameter holes in the front left and right corners of the base. The liners should be flush with the exterior wall. The air terminal plate may be recessed up to a maximum of 3/4" into the exterior wall or siding.

4. From outside, apply a bead of the high temperature sealant to the inside of both liners, approximately 1" from the end of each liner.

5. Holding the air terminal (lettering in an upright, readable position), insert into both liners with a twisting motion to ensure that both the terminal sleeves engage into the liners / sealant. Secure the terminal to the exterior wall and make weather tight by sealing with caulking (not supplied).

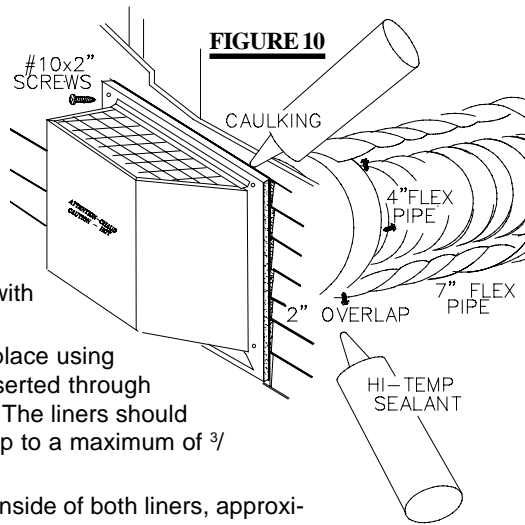

EXTENDED HORIZONTAL AND CORNER AIR TERMINAL INSTALLATION

A 45° corner installation must have 6 inch minimum rise between the fireplace combustion air collar and the air terminal. FIGURE 2d. In this case, vent lengths must be kept to a maximum of 36". For longer vent lengths, a minimum vertical rise of 24" is required. FIGURE 2c. Use the GD220 vent kit and couplers for this application.

1. Follow the instructions for "Horizontal Air Terminal Installations", items 1 through 5.

Spacers are attached to the 4" inner flex liner at predetermined intervals to maintain a 1-1/4" air gap to the 7" outer liner. These spacers must not be removed.

2. The vent system must be supported approximately every 3 feet for both vertical and horizontal runs. Use Napoleon support ring assemblies, GA-GD-010.370 or equivalent noncombustible strapping to maintain the minimum 1" clearance to combustibles.

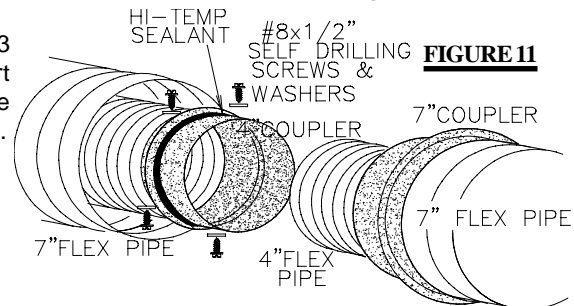

VERTICAL VENTING INSTALLATION

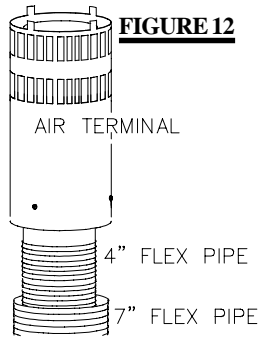

FIGURE 12

1. Fasten the roof support to the roof using the screws provided. The roof support is optional. In this case the venting is to be adequately supported using either an alternate method suitable to the authority having jurisdiction or the optional roof support.

2. Stretch the 4" diameter aluminum flexible liner to the required length. Slip the liner a minimum of 2" over the inner sleeve of the air terminal and secure with 3 #8 screws. Seal using a heavy bead of the high temperature sealant.

3. Repeat using 7" diameter aluminum flexible liner. **FIGURE 12.**

4. Thread the air terminal pipe assembly down through the roof. The air terminal must be located vertically and plumb. Attach the air terminal assembly to the roof support, ensuring that a minimum 16" of air terminal will penetrate the roof when fastened.

DO NOT CLAMP THE FLEXIBLE ALUMINUM LINER.

5. Remove nails from the shingles, above and to the sides of the chimney. Place the flashing over the air terminal and slide it underneath the sides and upper edge of the shingles. Ensure that the air terminal is properly centered within the flashing, giving a 3/4" margin all around. Fasten to the roof. Do **not** nail through the lower portion of the flashing. Make weather-tight by sealing with caulking. Where possible, cover the sides and top edges of the flashing with roofing material.

6. Apply a heavy bead of weatherproof caulking 2 inches above the flashing. Slide the storm collar around the air terminal and down to the caulking. Tighten to ensure that a weather-tight seal between the air terminal and the collar is achieved. Attach the other storm collar centered between the air intake and the air exhaust slots onto the air terminal. Tighten securely. **FIGURE 13.** Attach the vertical rain cap.

Spacers are attached to the 4" inner flex liner at predetermined intervals to maintain a 1-1/4" air gap to the 7" outer liner. These spacers must not be removed.

7. If more liner needs to be used to reach the fireplace, follow the same procedure as found in **EXTENDED HORIZONTAL AND CORNER AIR TERMINAL INSTALLATION.** The vent system must be supported approximately every 3 feet for both vertical and horizontal runs. Use Wolf Steel support ring assembly **GA-GD-010.370** or equivalent noncombustible strapping to maintain a clearance to combustibles of 1".

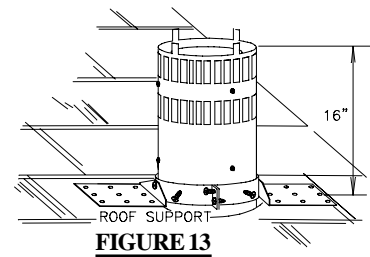

FIGURE 13

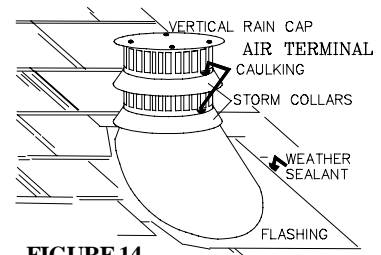

FIGURE 14

10 INSTALLATION

USING RIGID VENT COMPONENTS

FOR SAFE AND PROPER OPERATION OF THE FIREPLACE, FOLLOW THE VENTING INSTRUCTIONS EXACTLY.
HORIZONTAL RUNS MAY HAVE A ZERO INCH RISE PER FOOT

The vent system must be supported approximately every 3 feet for both vertical and horizontal runs. Use Napoleon vent spacers **WS-615-33** or equivalent every 3 feet and either side of each elbow to maintain the minimum 1¼" clearance between the outer and inner vent pipes. Use Napoleon support ring assembly **GA-GD-010.370** or equivalent noncombustible strapping to maintain the minimum 1" clearance to combustibles for both vertical and horizontal runs.

HORIZONTAL AIR TERMINAL INSTALLATION

1. Move the fireplace into position. Measure the vent length required between terminal and fireplace taking into account the additional length needed for the finished wall surface and any 1¼" overlaps between venting components.

2. Apply high temperature sealant to the outer edge of the 4" inner collar of the fireplace. Attach the first vent component and secure using 3 self tapping screws. Repeat using 7" piping.

3. Holding the air terminal (lettering in an upright, readable position), insert into both vent pipes with a twisting motion to ensure that both the terminal sleeves engage into the vent pipes and the sealant. Secure the terminal to the exterior wall and make weather tight by sealing with caulking (not supplied). The air terminal mounting plate must not be recessed into the exterior wall or siding.

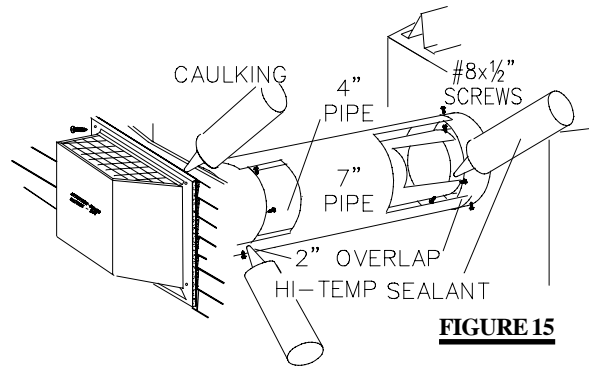

FIGURE 15

EXTENDED HORIZONTAL AND CORNER AIR TERMINAL INSTALLATION

A 45° corner installation can have 6 inch minimum rise between the fireplace combustion air collar and the air terminal. In this case, vent lengths must be kept to a maximum of 36". For longer vent lengths, a minimum vertical rise of 24" is required. **FIGURE 2c.**

1. Follow the instructions for "Horizontal Air Terminal Installations", items 1 to 2.

2. Continue adding components alternating inner and outer venting. Ensure that all 4" venting and elbows have sufficient vent spacers attached and each component is securely fastened to the one prior. Attach the 4" telescopic sleeve to the vent run. Repeat using a 7" telescopic sleeve. Secure and seal as before. To facilitate completion, attach 4" and 7" couplers to the air terminal.

3. Install the air terminal. See *item 3 above*. Extend the 4" telescopic sleeve; connect to the air terminal assembly. Fasten with self tapping screws and seal. Repeat using the 7" telescopic sleeve.

Elbows and rigid 36" lengths are manufactured with the 4" components permanently fixed within the 7" components. apply high temperature sealant to both collars and install the assembly as a single unit securing the outer 7" piece with three screws.

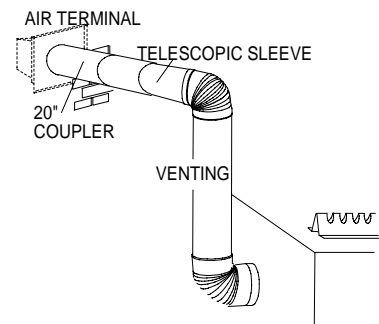

FIGURE 16

VERTICAL VENTING INSTALLATION

1. Move the fireplace into position.

2. Fasten the roof support to the roof using the screws provided. The roof support is optional. In this case the venting is to be adequately supported using either an alternate method suitable to the authority having jurisdiction or the optional roof support.

3. Apply high temperature sealant to the outer edge of the inner sleeve of the air terminal. Slip a 4" diameter coupler a minimum of 2" over the sleeve and secure using 3 screws.

4. Apply high temperature sealant to the outer edge of the of the outside sleeve of the air terminal. Slip a 7" diameter coupler over the sleeve and secure as before. Trim the 7" coupler even with the 4" coupler end.

5. Thread the air terminal pipe assembly down through the roof support and attach, ensuring that a minimum 16" of air terminal will penetrate the roof when fastened. **If the attic space is tight, we recommend threading the Wolf Steel vent pipe collar or equivalent loosely onto the air terminal assembly as it is passed through the attic.** FIGURE 19. The air terminal must be located vertically and plumb.

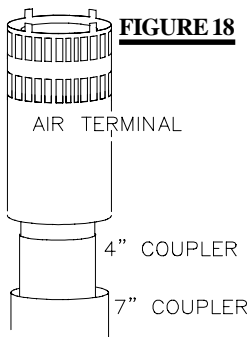

6. Remove nails from the shingles, above and to the sides of the chimney. Place the flashing over the air terminal and slide it underneath the sides and upper edge of the shingles. Ensure that the air terminal is properly centered within the flashing, giving a 3/4" margin all around. Fasten to the roof. Do NOT nail through the lower portion of the flashing. Make weather-tight by sealing with caulking. Where possible, cover the sides and top edges of the flashing with roofing material.

7. Apply a heavy bead of waterproof caulking 2 inches above the flashing. Slide the storm collar around the air terminal and down to the caulking. Tighten to ensure that a weather-tight seal between the air terminal and the collar is achieved. Attach the other storm collar centered between the air intake and air exhaust slots onto the air terminal. Tighten securely. Attach the rain cap.

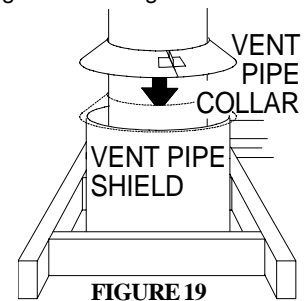
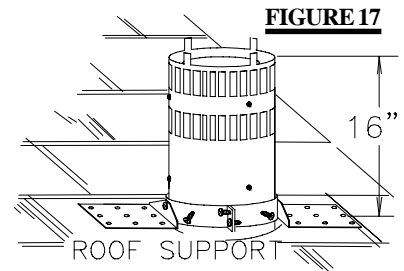
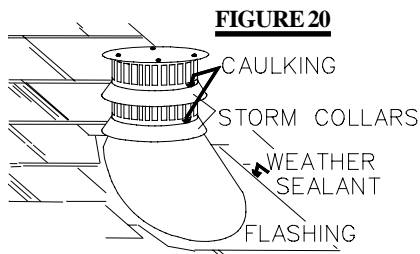

7. Apply a heavy bead of waterproof caulking 2 inches above the flashing. Slide the storm collar around the air terminal and down to the caulking. Tighten to ensure that a weather-tight seal between the air terminal and the collar is achieved. Attach the other storm collar centered between the air intake and air exhaust slots onto the air terminal. Tighten securely. Attach the rain cap.

8. Continue adding rigid venting sections, sealing and securing as above. Attach a 4" collapsed telescopic pipe to the last section of rigid piping. Secure with screws and seal. Repeat using a 7" telescopic pipe.

9. Run a bead of high temperature sealant around the outside of the 4" elbow. Pull the adjustable pipe a minimum 2" onto the elbow. Secure with 3 screws. Repeat with the 7" telescopic pipe.

10. In the attic, slide the vent pipe collar down to cover up the open end of the shield and tighten. This will prevent any materials, such as insulation, from filling up the 1" air space around the pipe.

12 GAS INSTALLATION

Proceed once the vent installation is complete.

1. Move the fireplace into position.
2. Route a 3/8" N.P.T. black iron gas line, 1/2" type-L copper tubing or equivalent to the fireplace.
3. For ease of accessibility, an optional remote wall switch or millivolt thermostat may be installed in a convenient location. Route 2-strand (solid core) millivolt wire through the electrical hole located at the bottom left side of the unit. The recommended maximum lead length depends on wire size:

WIRE SIZE	MAX. LENGTH
14gauge	100 feet
16gauge	60 feet
18gauge	40 feet

FIGURE 21

Attach the two leads to terminals 1 and 3 located on the gas valve.
FIGURE 21.

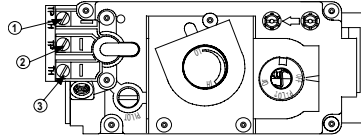

DO NOT CONNECT EITHER THE WALL SWITCH, THERMOSTAT OR GAS VALVE TO ELECTRICITY (110 VOLTS).

4. Install rigid black pipe, 1/2" type-L copper tubing or, if local codes permit, a 3/8" flex connector and shutoff valve to the gas line and the fireplace gas valve. Seal and tighten securely. An adapter fitting is required between the gas valve and the copper tubing or flex connector.

DO NOT KINK FLEX CONNECTOR. FIGURE 22.

5. Check for gas leaks by brushing on a soap and water solution.

DO NOT USE OPEN FLAME.

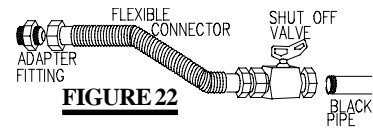

PURGE ALL GAS LINES WITH THE GLASS DOOR OF THE FIREPLACE REMOVED. ASSURE THAT A CONTINUOUS GAS FLOW IS AT THE BURNER BEFORE RE-INSTALLING THE DOOR.

MOBILE HOME INSTALLATION

In Canada, mobile home installation may be vented horizontally or vertically. In the United States, it may only be installed vertically. See "Vertical Venting" or "Horizontal Air Terminal Installation" for installation. To vent the fireplace vertically, a vent length of *3 feet minimum to 10 feet maximum* may be used only.

The fireplace is equipped with two 1/4" diameter holes located in the front left and right corners of the base. For mobile home installations, the fireplace must be fastened in place. Use #10 screws, inserted through the holes in the base to secure. It is recommended that the fireplace be secured in all installations.

Always turn the pilot and the fuel supply at the source off prior to moving the mobile home.

After moving the mobile home and prior to lighting the fireplace, ensure that the logs are positioned correctly.

FRAMING

It is best to frame your fireplace after it is positioned and the vent system is installed. Use 2x4's and frame to local building codes. **FIGURE 23-26.**

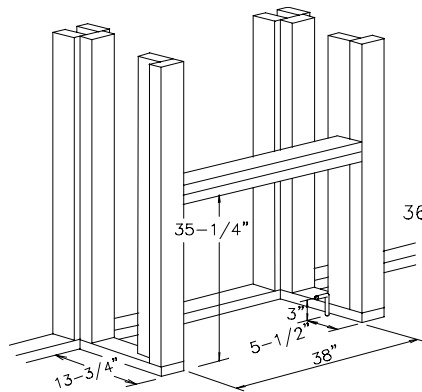

FIGURE 23

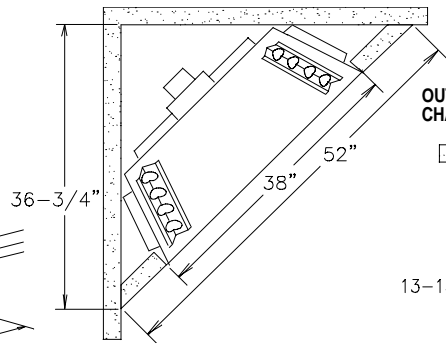

FIGURE 24

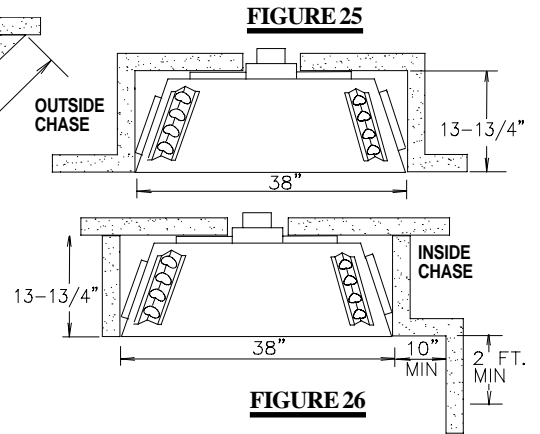

FIGURE 26

To install the fireplace face flush with the finished wall, position the framework to accommodate the thickness of the finished wall. For corner installation, allow a minimum rise of 6 inches between the fireplace and the air terminal. **FIGURE 2d.** Pull out the four nailing tabs, attached on either side of the fireplace and secure to the 2x4 framing to facilitate drywall installation.

Combustible materials must be installed flush with the front of the fireplace but must not cover any of the black face-area of the fireplace. Non-combustible material (brick, stone or ceramic tile) may protrude.

It is not necessary to install a hearth extension with this fireplace system. Objects placed in front of the fireplace should be kept a minimum of 24" away from the front face.

Mantle clearance can vary according to the mantle depth. **FIGURE 27.** Use the graph to help evaluate the clearance needed.

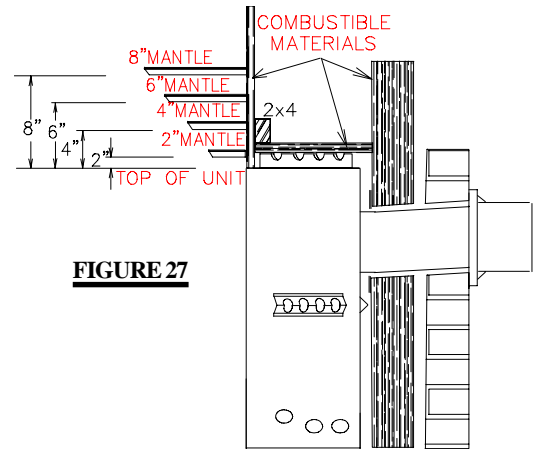
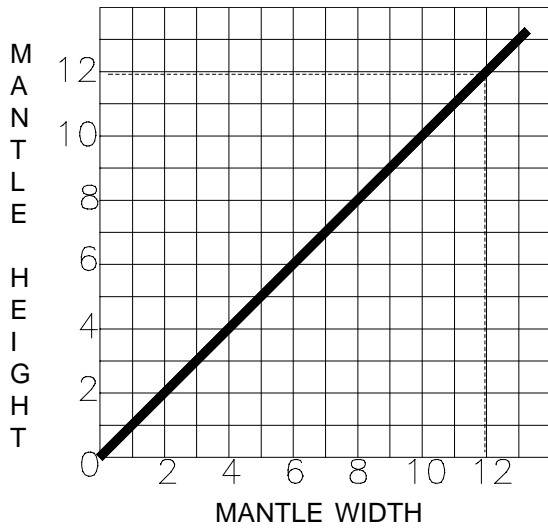

FIGURE 27

14 FINISHING

LOG PLACEMENT

PHAZER™ logs and glowing embers (available as an option from your Napoleon dealer), exclusive to Napoleon Fireplaces, provide a unique and realistic glowing effect that is different in every installation. Take the time to carefully position the glowing embers for a maximum glowing effect.

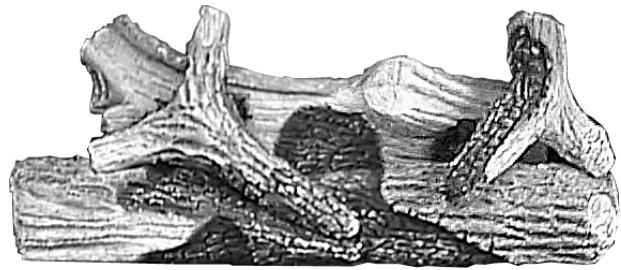
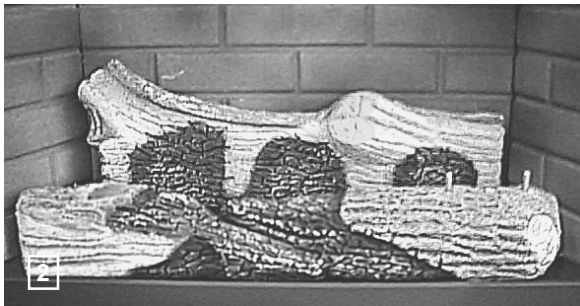

FIGURE 28



1. Place the front log, as shown, centered along the inside front edge of the burner tray.



2. Place the back log onto the log support bracket, located on the rear wall of the combustion chamber, pushing it as close to the firebox wall as possible.



3. & 4. Set the two smaller logs into the pockets and pegs of the front and back logs, respectively.

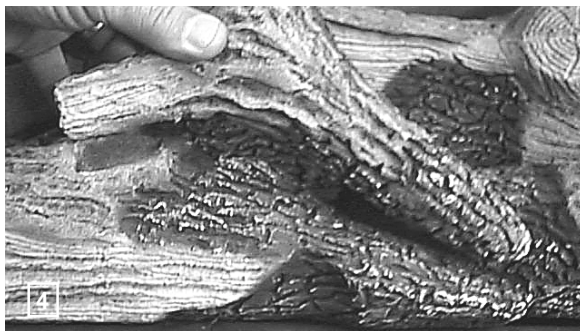

Log colours may vary. During the initial use of the fireplace, the colours will become more uniform as colour pigments burn in during the heat activated curing process.

POSITIONING THE LOGS IMPROPERLY WILL CAUSE FLAME IMPINGEMENT AND CARBONING.

OPTIONAL GLOWING EMBER INSTALLATION

Tear the embers into pieces and place beneath the front log covering all of the burner area beneath and in front of the hollowed out section of the log. Care should be taken to shred the embers into thin, small irregular pieces as only the exposed edges of the fibre hairs will glow.

THE EMBER MATERIAL WILL ONLY GLOW WHEN EXPOSED TO DIRECT FLAME; HOWEVER, CARE SHOULD BE TAKEN TO NOT BLOCK THE BURNER PORTS.

Blocked burner ports can cause an incorrect flame pattern, carbon deposits and delayed ignition. **PHAZER™** logs glow when exposed to direct flame. Use only certified "glowing embers" and **PHAZER™** logs available from your Napoleon / Wolf Steel Ltd. dealer.

DOOR, LOUVRE AND TRIM REMOVAL & INSTALLATION

ENSURE THAT THE DOOR IS PROPERLY CLIPPED ONTO THE STEEL LIP TO PREVENT OVERHEATING, GLASS BREAKAGE AND/OR DISCOLOURATION OF THE UPPER TRIM.



FIGURE 29

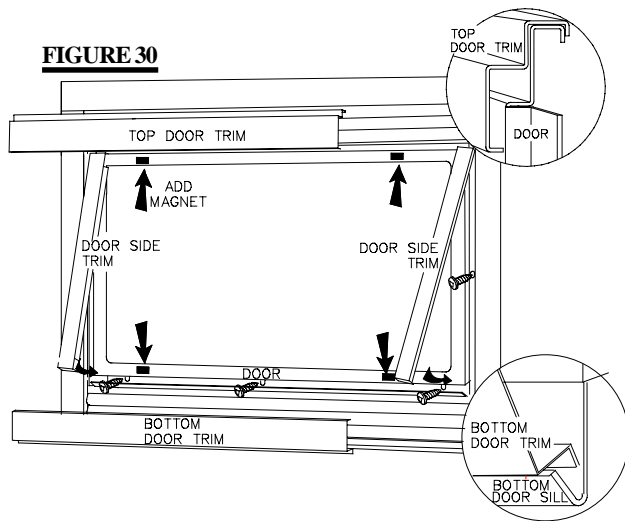

FIGURE 30

DOOR REMOVAL: Both top and bottom door trim must be removed prior to door removal. Lift up the top trim and unhook from the door. The bottom trim may be pulled off and lifted out of the bottom door sill. **FIGURE 30.**

Remove the five screws securing the sides and bottom of the door. Lift up and out.

DOOR AND TRIM INSTALLATION: When re-installing, re-tighten screws snugly. **DO NOT OVER-TIGHTEN.**

Hang the door side trim onto each door side with the notches towards the centre of the unit. The top and bottom door trim may be installed next. Attach magnets to the top and bottom door trim approximately 4" from either end. Lift up the top trim and hook over the top of the door. The bottom trim is inserted into the bottom door sill. Push in to engage the magnets. Centre both side trims.

LOUVRES: The louvre assemblies are installed as illustrated in **FIGURE 31**. Optional arched door facias are available at your local Napoleon/ Wolf Steel dealer.

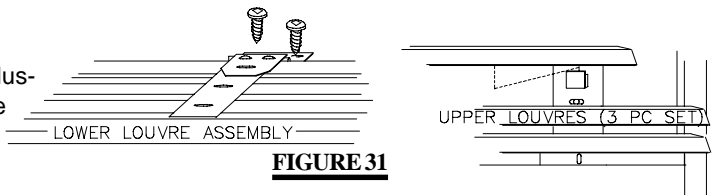

FIGURE 31

16 OPTIONAL BLOWER INSTALLATION

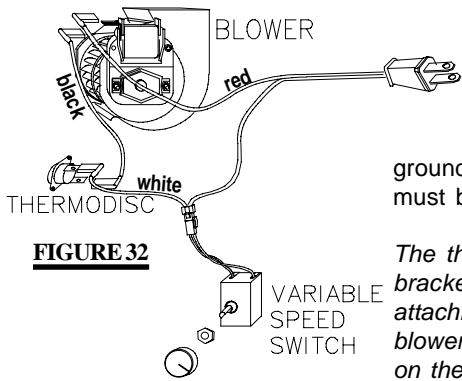

FIGURE 32

INSTALLATION TO BE DONE BY A QUALIFIED INSTALLER and must be electrically connected and grounded in accordance with local codes. In the absence of local codes, use the current CSA C22.1 CANADIAN ELECTRICAL CODE in Canada or the ANSI/NFPA 70-1996 NATIONAL ELECTRICAL CODE in the United States. **If the fireplace was not previously equipped with a blower:** route a grounded 2-wire, 60hz power cable to the receptacle / junction box. At this point, it must be strain relieved and insulated.

The three slots on the blower mounting bracket allow ease of adjustment when attaching the blower. For a quiet running blower, do not allow the assembly to sit on the firebox base.

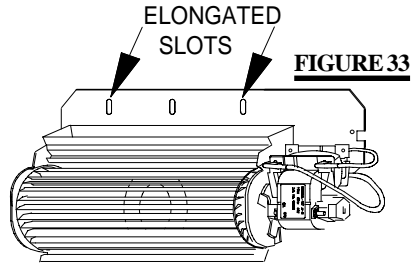

FIGURE 33

Slide the vibration reducing pad (A) into the clip (C) and onto the threaded stud (B) at the other end, piercing a hole into the pad. The blower must be able to be positioned entirely onto the pad.

Tilt the blower onto its side. Slide it past the controls and into the clip (C). Secure to the threaded stud using the lock washer and wing nut provided. Ensure that the blower does not touch the fireplace base or the firebox. Attach the connectors from the black and white wires to the thermodisc and secure the thermodisc bracket to the securing stud at the bottom left of the unit using a lock washer and wing nut. Ensure that the thermodisc touches the firebox wall.

Attach the connectors from the black and red wires to the blower.

Attach and secure the variable speed switch using the nut provided. Plug the harness cord into the receptacle.

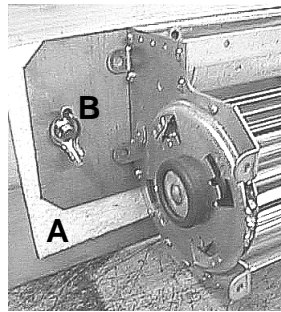

FIGURE 34

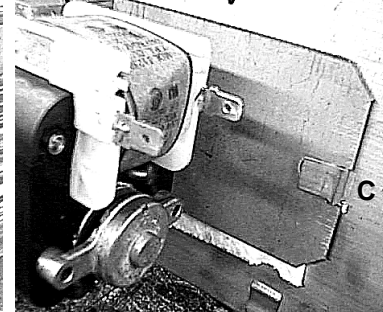

FIGURE 35

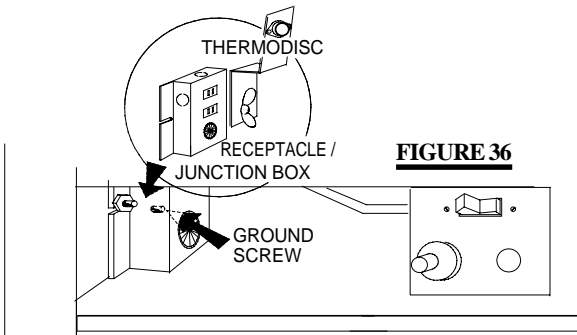

FIGURE 36

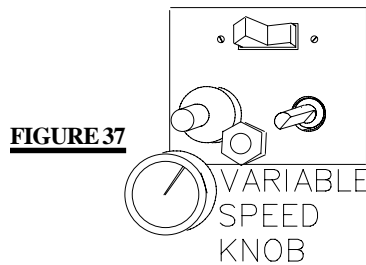

FIGURE 37

The wire harness provided in this kit is a universal harness. When installed, ensure that any excess wire is contained, preventing it from making contact with moving or hot objects.

Because the blower is thermally activated, when turned on, it will automatically start approximately 10 minutes after lighting the fireplace and will run for approximately 30-45 minutes after the fireplace has been turned off. Use of the fan increases the output of heat.

OPTIONAL FAN INSTALLATION ¹⁷

ELECTRICAL INSTALLATION TO BE DONE BY A QUALIFIED INSTALLER and must be connected and grounded in accordance with local codes. In the absence of local codes, use the current CSA C22.1 CANADIAN ELECTRICAL CODE in Canada or the ANSI/NFPA 70-1990 NATIONAL ELECTRICAL CODE in the United States.

If the fireplace was not previously equipped with a fan: route a grounded 2-wire, 60hz power cable to the junction box. At this point, it must be strain relieved and insulated.

The wire harness provided in this kit is a universal harness. When installed, ensure that any excess wire is contained, preventing it from making contact with moving or hot objects.

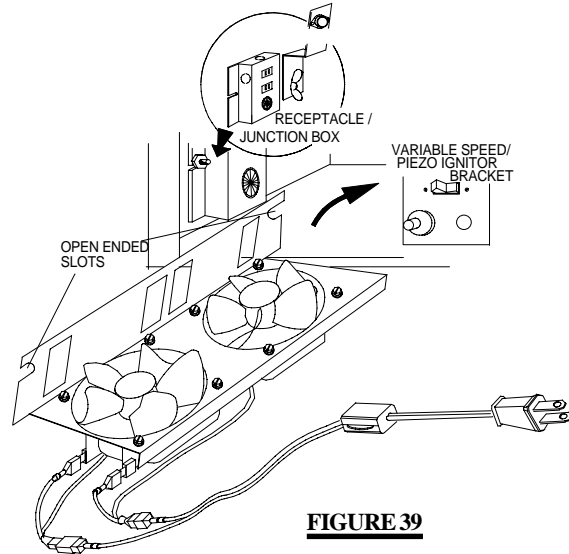

FIGURE 39

Position the vibration reducing pad into the clip and onto the threaded stud at the other end, piercing a hole into the pad. The fan assembly must be able to be positioned entirely onto the pad.

Slide the fan assembly past the controls and into the clip. Secure using the lock washer and nut provided.

Attach the connectors from the black and white wires to the thermodisc and secure the thermodisc bracket to the securing stud at the bottom left of the unit using a lock washer and wing nut. Ensure that the thermodisc touches the firebox wall.

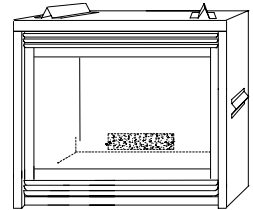

FIGURE 38

GD36 THERMOSTATIC SENSOR CONTROL

This optional kit is meant to be used only in conjunction with the GD65 Fan Kit, shown above, which may be ordered from your Wolf Steel / Napoleon dealer.

With the thermostatic sensor option, the fan, when turned on, becomes thermally activated, and will automatically run approximately 15-30 minutes after the fireplace has been lit and for approximately 30-45 minutes after the fireplace has been turned off.

Use of the fan increases the output of heat.

Unplug the power cord from the receptacle. Connect all wires as shown. Attach and secure the sensor assembly bracket to the securing stud located next to the receptacle/junction box at the bottom left of the unit using the lock washer and wing nut. Ensure that the thermodisc touches the firebox wall. Plug the power cord back into the receptacle.

When installed, ensure that any excess wire is contained, preventing it from making contact with moving or hot objects.

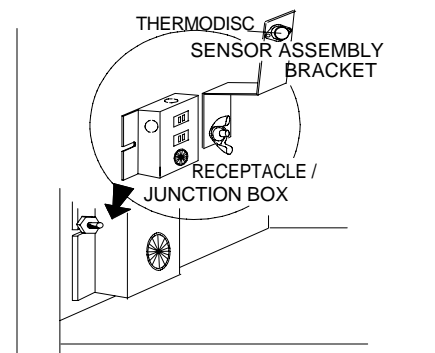

FIGURE 40

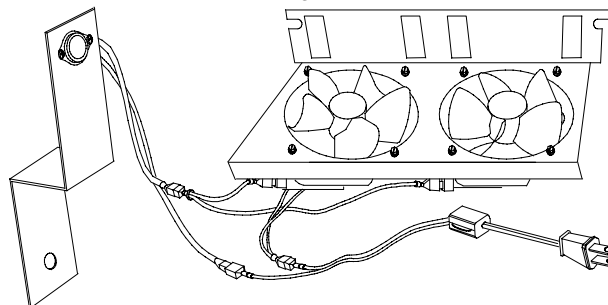

FIGURE 41

18 OPERATION / MAINTENANCE

When lit for the first time, the fireplace will emit a slight odour for a few hours. This is a normal temporary condition caused by the curing of the logs and the "burn-in" of internal paints and lubricants used in the manufacturing process and will not occur again. Simply open a window to sufficiently ventilate the room.

After extended periods of non-operation such as following a vacation or a warm weather season, the fireplace may emit a slight odour for a few hours. This is caused by dust particles in the heat exchanger burning off. Open a window to sufficiently ventilate the room.

FOR YOUR SAFETY READ BEFORE LIGHTING:

- A This fireplace has a pilot which must be lit by hand while following these instructions exactly.
- B Before lighting, smell all around the fireplace area for gas and next to the floor because some gas is heavier than air and will settle on the floor.
- C Use only your hand to push in or turn the gas control knob. Never use tools. If the knob will not push in or turn by hand, Do not try to repair it. Call a qualified service technician. Force or attempted repair may result in a fire or explosion.
- D Do not use this fireplace if any part has been under water. Immediately call a qualified service technician to inspect the unit and replace any part of the control system and any gas control touched by water.



WHAT TO DO IF YOU SMELL GAS:

- Do not try to light any appliance.
- Do not touch any electrical switch; do not use any phone in your building.
- Immediately call your gas supplier from a neighbour's phone. Follow the gas supplier's instructions.
- If you cannot reach your gas supplier, call the fire department.

LIGHTING INSTRUCTIONS

WARNING: The gas valve has an interlock device which will not allow the pilot burner to be lit until the thermocouple has cooled. Allow approximately 60 seconds for the thermocouple to cool.

When lighting and re-lighting, the gas knob cannot be turned from pilot to off unless the knob is **depressed slightly**.

1. Stop! Read the above safety information on this label.
2. Turn off all electric power to the fireplace.
3. Turn the gas knob clockwise  to off.
4. Wait five (5) minutes to clear out any gas. If you smell gas including near the floor. Stop! Follow "B" in the above safety information on this label. If you don't smell gas go the next step.
5. Turn gas knob counter-clockwise  to pilot.
6. Depress slightly and hold gas knob while lighting the pilot with the push button ignitor. Keep knob depressed for one minute, then release. If pilot does not continue to burn, repeat steps 3 through 5.
7. With pilot lit, depress and turn gas knob counter-clockwise  to on.
8. If equipped with remote on-off switch/thermostat, main burner may not come on when you turn valve to on. Remote switch must be in the on position to ignite burner.
9. Turn on all electric power to the fireplace.

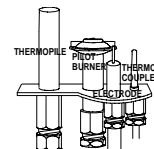
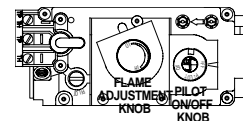

INSTRUCTIONS TO TURN OFF GAS:

1. Turn off all electrical power to the unit if service is to be performed.
2. Push in gas control knob slightly and turn clockwise  to off. DO NOT FORCE.

MAINTENANCE TURN OFF THE GAS AND ELECTRICAL POWER BEFORE SERVICING THE FIREPLACE.

CAUTION: Label all wires prior to disconnection when servicing controls. Wiring errors can cause improper and dangerous operation. Verify proper operation after servicing. This fireplace and its venting system should be inspected before use and at least annually by a qualified service person. The fireplace area must be kept clear and free of combustible materials, gasoline or other flammable vapours and liquids. The flow of combustion and ventilation air must not be obstructed.

1. In order to properly clean the burner and pilot assembly, remove the logs to expose both assemblies.
2. Keep the control compartment, logs, burner, air shutter opening and the area surrounding the logs clean by vacuuming or brushing, *at least once a year*.
3. Check to see that all burner ports are burning. Clean out any of the ports which may not be burning or are not burning properly.
4. Check to see that the pilot flame is large enough to engulf the thermopile on one leg and reaches toward the burner on the other leg.
5. Replace the cleaned logs.
6. Check to see that the main burner ignites completely on all openings when the gas knob for the burner is turned on. A 5 to 10 second total light-up period is satisfactory. If ignition takes longer, consult your Napoleon dealer / distributor.
7. Check that the gasketing on the sides, top and bottom of the door is not broken or missing. Replace if necessary.

ADJUSTMENTS

PILOT BURNER ADJUSTMENT

Adjust the pilot screw to provide properly sized flame. Turn in a clockwise direction to reduce the gas flow. FIGURES 42 & 43.

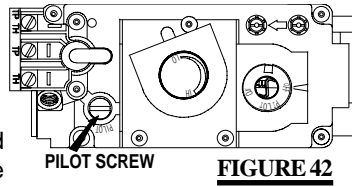

FIGURE 42

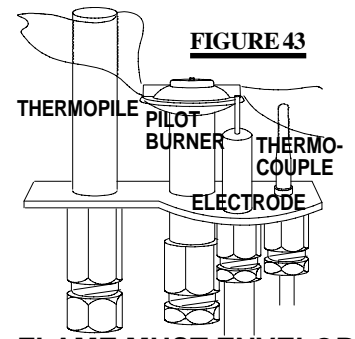

FIGURE 43

FLAME MUST ENVELOP UPPER 3/8" TO 1/2" OF THERMOCOUPLE & THERMOPILE

VENTURI ADJUSTMENT

Natural gas models have air shutters set at 1/4 (.250") inch open. Propane gas models have air shutters set at 3/8 (.375) inch open. Closing the air shutter will cause a more yellow flame, but can lead to carboning. Opening the air shutter will cause a more blue flame, but can cause flame lifting from the burner ports. The flame may not appear yellow immediately; allow 15 to 30 minutes for the final flame colour to be established. FIGURE 44.

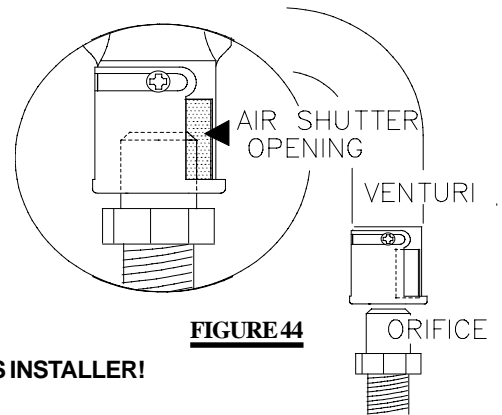

FIGURE 44

AIR SHUTTER ADJUSTMENT MUST ONLY BE DONE BY A QUALIFIED GAS INSTALLER!

NOTES:

20 REPLACEMENTS

ORDERING REPLACEMENT PARTS

Contact your dealer or the factory for questions concerning prices and policies on replacement parts. Normally all parts can be ordered through your Napoleon dealer or distributor. When ordering replacement parts always give the following information:

1. Model & Serial Number of fireplace
2. Installation date of fireplace
3. Part Number
4. Description of part
5. Finish

REPLACEMENT PARTS FOR WARRANTY REPLACEMENT PARTS, A PHOTOCOPY OF THE ORIGINAL INVOICE WILL BE REQUIRED TO HONOUR THE CLAIM.

PART NO.	DESCRIPTION
WS-135-053	BACK LOG
WS-135-054	FRONT LOG
WS-135-056	RIGHT LOG
WS-135-055	LEFT LOG
GL-617	LOG SET ASSEMBLY
WS-385-33	NAPOLEON LOGO
WS 573-008	HIGH TEMPERATURE SEALANT
WS 100-35	BURNER
WS 455-23	NATURAL GAS PILOT ORIFICE
WS 455-24	PROPANE GAS PILOT ORIFICE
WS 725-25	NATURAL GAS VALVE
WS-725-26	PROPANE GAS VALVE
WS-430-001	CERAMIC MAGNET
GD660	STANDARD WALL SWITCH & 20FT OF WIRE
GA GD 715.11	POLISHED BRASS UPPER LOUVRE
GA GD 010.391	POLISHED BRASS LOWER LOUVRE ASSEMBLY
WS-660-5	ON/OFF TOGGLE SWITCH
GA GD 225.36	BLACK DOOR FRAME
WS 300-20	GLASS ONLY
GA GD 321K	BLACK DOOR C/W GLASS
GA-GD-010.454	GLASS c/w GASKET
GD-562.09	DOOR GASKET (105 INCHES)
GA-GD-020.042	PKG OF 5 DOOR SCREWS
GA GD 010.376	BOTTOM DOOR TRIM
GA GD 715.136	TOP DOOR TRIM
WS-100-39	PROPANE GAS PILOT ASSEMBLY
WS 100-38	NATURAL GAS PILOT ASSEMBLY
WS 455-03	#54 PROPANE GAS ORIFICE
WS 455-040	#41 NATURAL GAS ORIFICE
WS-750-09	IGNITER WIRE
WS 357-01	PIEZO IGNITER
WS 680-04	THERMOPILE
WS-680-05	THERMOCOUPLE

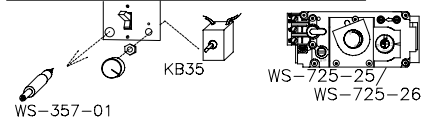
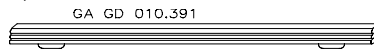
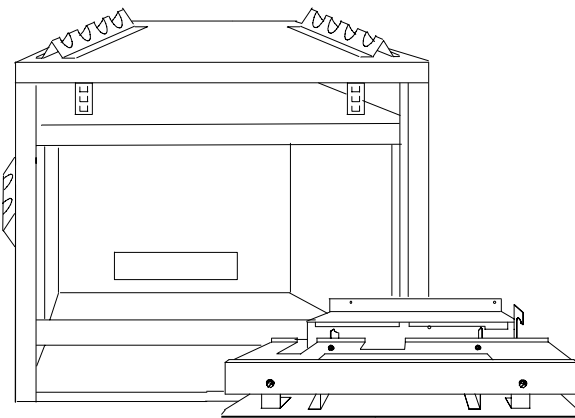
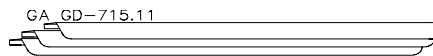
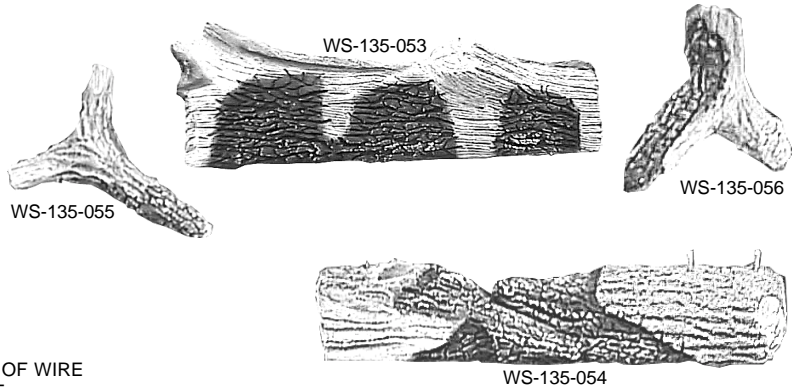

VENT KITS

GD220 (5 FOOT)

PART NO.	DESCRIPTION
GD-010.397	4" FLEXIBLE ALUMINUM LINER (5 FT)c/w SPACERS
WS 410-17	7" FLEXIBLE ALUMINUM LINER (5 FT)

GD330 (10 FOOT)

PART NO.	DESCRIPTION
GS 10.300	4" FLEXIBLE ALUMINUM LINER (10 FT)c/w SPACERS
WS 410-018	7" FLEXIBLE ALUMINUM LINER (10 FT)
GD10.370	WALL SUPPORT ASSEMBLY

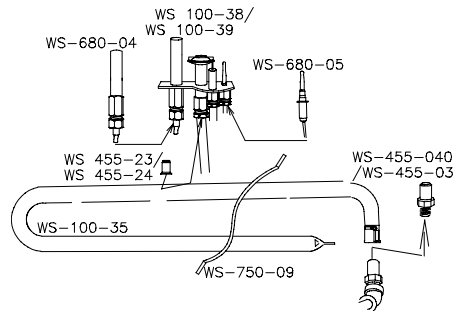
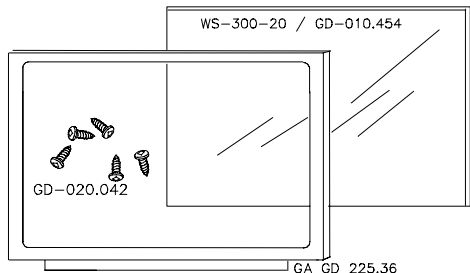

TERMINAL KITS

ROOF TERMINAL KITS: 1/12 TO 7/12 PITCH - GD110
8/12 TO 12/12 PITCH - GD111
FLAT ROOF - GD112

PART NO.	DESCRIPTION
GA GD10.210	AIR TERMINAL
GA GD 120.036	VERTICAL CAP
WS-170-063	STORM COLLAR
GA-GD-010.453	ROOF SUPPORT
WS-263-054 / WS-263-055 / WS-263-056	ROOF FLASHING

PERISCOPE - GD201

WALL TERMINAL KIT - GD222

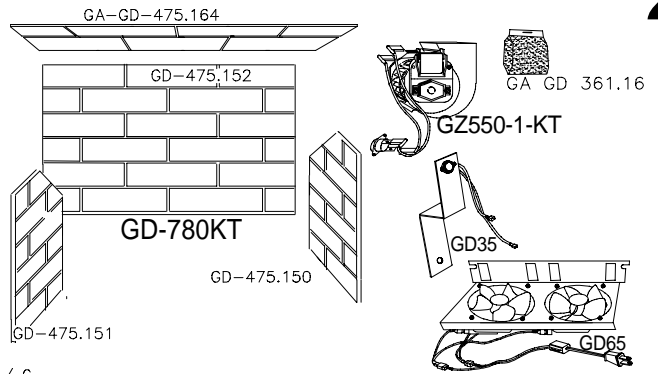

ACCESSORIES

PART NO.	DESCRIPTION
GA GD 500.96	FIRESTOP - FLEXIBLE VENTING
GA GD 500.136	FIRESTOP - RIGID VENTING
GD 101	WINDSHIELD KIT
GD 301	HEAT GUARD
GD 303	VINYL SIDING SHIELD
GA GD 10.370	WALL SUPPORT ASSEMBLY
GD 225K	DOOR FACIA - BLACK
GD 225PB	DOOR FACIA - POLISHED BRASS
GD 225AB	DOOR FACIA - ANTIQUE BRASS
GD 225C	DOOR FACIA - CHROME
GD250-K	WEBBED DOOR FACIA
GA-GDLK	BLACK LOUVRE KIT
GA-GDLPB	POLISHED BRASS LOUVRE KIT
GA-GDLAB	ANTIQU BRASS LOUVRE KIT
GA-GDLC	CHROME LOUVRE KIT
WS 660-02	HAND HELD WIRELESS REMOTE SWITCH
GZ550-1-KT	BLOWER KIT
KB35	VARIABLE SPEED SWITCH
WS 500-33	V.S.S. MOUNTING PLATE FOR WALL SWITCH
GD203	DOOR SIDE TRIM
WS-175-053	DURA-VENT ZERO CLEARANCE ADAPTOR
WS-660-010	REMOTE CONTROL - ADVANTAGE
WS-660-011	REMOTE CONTROL - ADVANTAGE PLUS
GA GD 2AB	2" TRIM KIT - ANTIQUE BRASS
GA GD 2PB	2" TRIM KIT - POLISHED BRASS
GA GD 2C	2" TRIM KIT - CHROME
GA GD 3AB	3" TRIM KIT - ANTIQUE BRASS
GA GD 3PB	3" TRIM KIT - POLISHED BRASS
GA GD 3C	3" TRIM KIT - CHROME
GA GD 6AB	6" TRIM KIT - ANTIQUE BRASS
GA GD 6PB	6" TRIM KIT - POLISHED BRASS
GA GD 6C	6" TRIM KIT - CHROME
GA GD 4AB	4" - 3D TRIM KIT - ANTIQUE BRASS
GA GD 4PB	4" - 3D TRIM KIT - POLISHED BRASS
WS 175-01	4" COUPLER
WS 175-13	7" COUPLER
WS 573-008	HI-TEMPERATURE SEALANT
GD202-PB	DOOR TRIM KIT - POLISHED BRASS
WS 690-01	MILLIVOLT THERMOSTAT
GA GD 361.16	GLOWING EMBERS
GD-780KT	DECORATIVE BRICK PANELS
GD320B-KT	BAY WINDOW KIT
WS 430-01	CERAMIC MAGNET

GD 225K / PB / AB / C

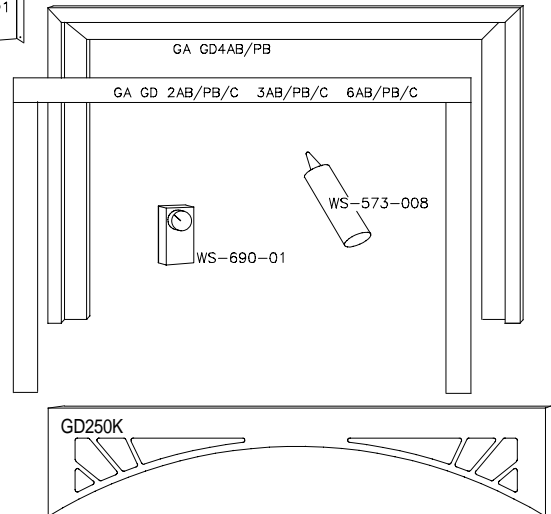
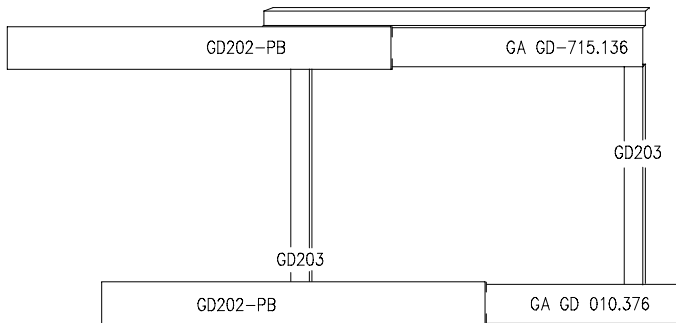
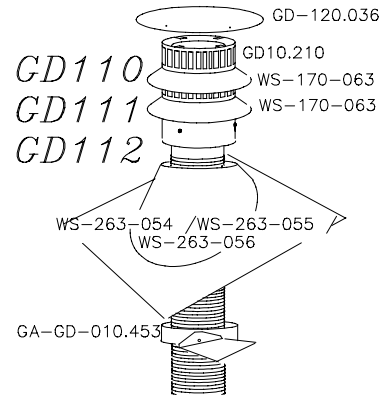
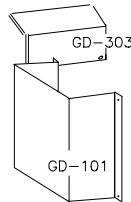
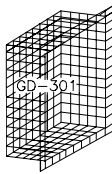
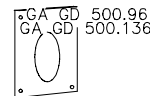
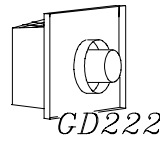
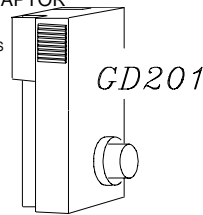
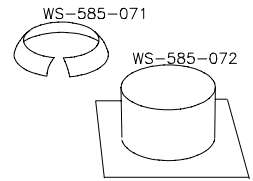
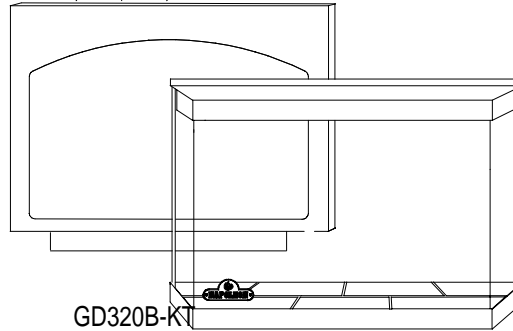

22 TROUBLE SHOOTING GUIDE

BEFORE ATTEMPTING TO TROUBLESHOOT, PURGE YOUR UNIT AND INITIALLY LIGHT THE PILOT AND THE MAIN BURNER WITH THE GLASS DOOR REMOVED.

SYMPTOM	PROBLEM	TEST SOLUTION
Main burner flame is a blue, lazy, transparent flame.	Blockage in vent.	- remove blockage. In really cold conditions, ice buildup may occur on the terminal and should be removed as required.
	Incorrect installation.	- refer to Figure 14 to ensure correct location of storm collars.
Carbon is being deposited on glass, logs or combustion chamber surfaces.	Air shutter has become blocked	- ensure air shutter opening is free of lint or other obstructions.
	Flame is impinging on the logs or combustion chamber.	- check that the logs are correctly positioned. - open air shutter to increase the primary air. - check the input rate: check the manifold pressure and orifice size as specified by the rating plate values. - check that the door gasketing is not broken or missing and that the seal is tight. - check that both 4" and 7" vent liners are free of holes and well sealed at all joints. - check that minimum rise per foot has been adhered to for any horizontal venting.
White / grey film forms.	Sulphur from fuel is being deposited on glass, logs or combustion chamber surfaces.	- clean the glass with a recommended gas fireplace glass cleaner. DO NOT CLEAN GLASS WHEN HOT. If deposits are not cleaned off regularly, the glass may become permanently marked.
Exhaust fumes smelled in room, headaches.	Fireplace is spilling.	- check door seal and relief flap seal. - check for chimney blockage - check that chimney is installed to building code. - room is in negative pressure; increase fresh air supply.
Pilot goes out when the gas knob is released. The gas valve has an interlock device which will not allow the pilot burner to be lit until the thermocouple has cooled. Allow approximately 60 seconds for the thermocouple to cool.	System is not correctly purged.	- purge the gas line.
	Out of propane gas.	- fill the tank.
	Pilot flame is not large enough	- turn up the pilot flame.
	Pilot flame is not engulfing the thermocouple.	- gently twist the pilot head to improve the flame pattern around the thermocouple.
	Thermocouple shorting / faulty.	- loosen and tighten thermocouple. - clean thermocouple and valve connection. - replace thermocouple. - replace valve.
	Faulty valve.	- replace.
Pilot burning; no gas to main burner; gas knob is on 'HI'; wall switch / thermostat is on.	Thermostat or switch is defective.	- connect a jumper wire across the wall switch terminals; if main burner lights, replace switch / thermostat.
	Wall switch wiring is defective.	- connect a jumper wire across terminals 1 & 3; if the main burner lights, check the wires for defects and / or replace wires.
	Main burner orifice is plugged.	- remove stoppage in orifice.
	Faulty valve.	- replace.
Pilot goes out while standing; Main burner is in 'OFF' position.	Gas piping is undersized.	- turn on all gas appliances and see if pilot flame flutters, diminishes or extinguishes, especially when main burner ignites. Monitor appliance supply working pressure. - check if supply piping size is to code. Correct all undersized piping.

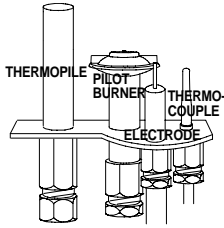
SYMPTOM	PROBLEM	TEST SOLUTION
Pilot will not light.	No spark at pilot burner	<ul style="list-style-type: none"> - check if pilot can be lit by a match - check that the wire is connected to the push button ignitor. - check if the push button ignitor needs tightening. - replace the wire if the wire insulation is broken or frayed. - replace the electrode if the ceramic insulator is cracked or broken. - replace the push button ignitor.
	Out of propane gas	- fill the tank.
	Spark gap is incorrect	<ul style="list-style-type: none"> - spark gap should be 0.150" to 0.175" (5/32" to 11/64" approx.) from the electrode tip and the pilot burner. To ensure proper electrode location, tighten securing nut (finger tight plus 1/4 turn).
	No gas at the pilot burner	<ul style="list-style-type: none"> - check that the manual valve is turned on. - check the pilot orifice for blockage. - replace the valve. - call the gas distributor.
Flames are consistently too large or too small. Carboning occurs.	Unit is over-fired or under-fired.	<ul style="list-style-type: none"> - check pressure readings: <p>Inlet pressure can be checked by turning screw (A) counter-clockwise 2 or 3 turns and then placing pressure gauge tubing over the test point. Gauge should read 7" (minimum 4.5") water column for natural gas or 13" (11" minimum) water column for propane. Check that main burner is operating on "HI".</p> <p>Outlet pressure can be checked the same as above using screw (B). Gauge should read 3.5" water column for natural gas or 10" water column for propane. Check that main burner is operating on "HI".</p> <p>AFTER TAKING PRESSURE READINGS, BE SURE TO TURN SCREWS CLOCKWISE FIRMLY TO RESEAL. DO NOT OVERTORQUE.</p> <p>Leak test with a soap and water solution.</p>
Main burner goes out; pilot stays on.	Pilot flame is not large enough or not engulfing the thermopile	<ul style="list-style-type: none"> - turn up pilot flame. - replace pilot assembly.
	Thermopile shorting	<ul style="list-style-type: none"> - clean thermopile connection to the valve. Reconnect. - replace thermopile / valve.
	Remote wall switch wire is too long; too much resistance in the system.	- shorten wire to correct length or wire gauge.
	Faulty thermostat or switch.	- replace.
Main burner goes out; pilot goes out.	Refer to "MAIN BURNER GOES OUT; PILOT STAYS ON"	
	Vent is blocked	- check for vent blockage.
	Vent is re-circulating	- check joint seals and installation.
	4" flexible vent has become disconnected from fireplace.	- re-attach to fireplace.
Remote wall switch is in "OFF" position; main burner comes on when gas knob is turned to "ON" position.	Wall switch is mounted upside down	- reverse.
	Remote wall switch is grounding.	- replace.
	Remote wall switch wire is grounding.	- check for ground (short); repair ground or replace wire.
	Faulty valve.	- replace.

